

Contents:
Stainless Steel Vents
Aluminium Vents

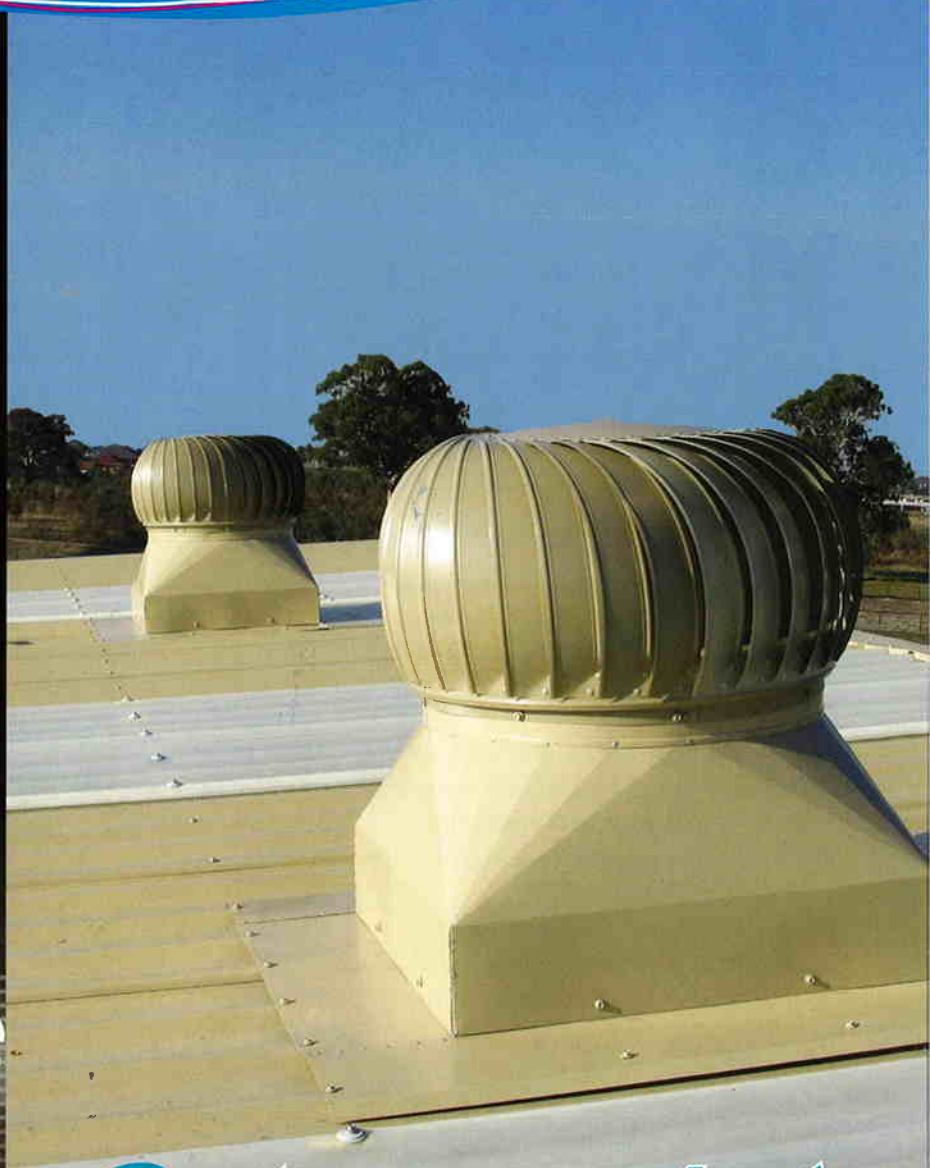

Superior stainless steel turbo ventilators provide effective low maintenance ventilation



Ampelair

- Wind driven
- No running costs
- Efficient design
- Reliable
- Resists corrosion
- Ten year warranty

- details from Ampelite offices



Ampelair Stainless Steel Ventilators give superior performance in corrosive environments – the simple answer on any roof

Ampelair



Wind driven turbo ventilators are used the world over because of their low capital and installed cost, adaptability, high capacity per vent, and reliability.

Operation is simplicity in itself. As the vent hood is rotated by the wind the stale inside air is exhausted through the vanes and the natural inward flow of air is boosted. Ampelair Rotary Ventilators are efficient, impressive and psychologically appealing due to their effortless spinning motion.



Ampelair Stainless Steel ventilators may be used to ventilate environments subject to harsh oxidative or slightly acidic (but not caustic) conditions. Constructed from 304 stainless steel they have features that make them ideal for the following applications:

- Exhausting pit gases, methane, sulphur dioxide etc.
- Minimising condensation under metal roofs covering water storage tanks or reservoirs.
- Removing chlorine fumes above enclosed swimming pools.
- Ventilating very gritty environments where air-borne particles may clog an exposed bottom bearing.
- Industrial ventilation when higher standards matter.

Features

- Stainless Steel bearings fully enclosed and self lubricating in a Stainless Steel double row casing.
- Bearings are maintenance free, designed to withstand extreme environments.
- Bearing assembly provides low friction with minimal drag, resulting in a longer life.
- Two part shaft system comprising anti corrosive steel axle fully sealed in a fire resistant nylon casing.
- The tough nylon casing ensures the original alignment of head and axle always conforms even after wind pressure stresses.
- The weather vane is designed to aerodynamic principles, enhancing performance.
- Optimum efficiency has been achieved through the vane's angle and enlarged surface area.
- Low profile design and Stainless Steel construction provides better aesthetics.
- Also available in powder coated colour finishes.
- Available models:
SS150, SS300, SS500, SS600, SS800.

Ventilators can be supplied complete with base to suit the application, or heads and bases may be ordered separately. Site surveys are available but you can use the following formulas to determine your requirements.

Calculations to decide size or number of Ventilators.

1. Determine the volume of the building.

Volume of section A = $0.5 \times L \times W \times H_a$

Volume of section B = $L \times W \times H_b$

Total building volume = volume of section A + volume of section B.

Note: For factories, the combined volume A + B should be used.

Where Volume B is airconditioned, only Volume A is used to calculate the number of ventilators required. No air should be drawn from the airconditioned space below ceiling level.

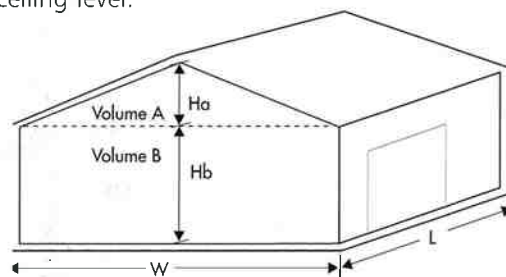

2. Select the number of ventilators required

$$\text{METRIC} = V \times A/ch$$

$$EX/c \times 3.6$$

Where:

V = volume of building or roof space

A/ch = air changes per hour

EX/c = Exhaust capacity of ventilator

Using ventilators in the ceiling space of airconditioned buildings reduces the load on the airconditioning plant and helps reduce power consumption accordingly.

Dimensions

VENTILATOR HEAD

SQUARE to ROUND BASE

VARIABLE PITCH BASE

All models and bases

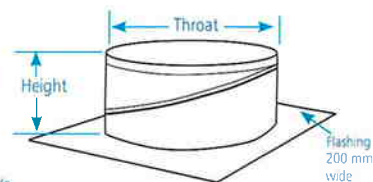
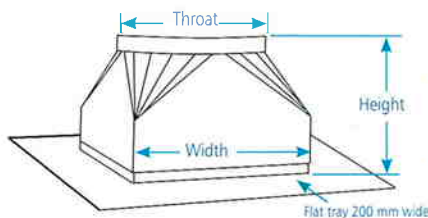
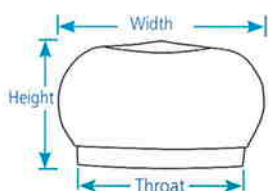

| Stainless Steel | Throat | Width | Height | Width | Height | Width | Height |
|-----------------|--------|--------|--------|--------|--------|--------|--------|
| SS150 | 150 mm | 230 mm | 210 mm | 210 mm | 210 mm | - | - |
| SS300 | 300 mm | 340 mm | 370 mm | 350 mm | 360 mm | 500 mm | 180 mm |
| SS500 | 500 mm | 640 mm | 320 mm | 610 mm | 415 mm | 750 mm | 190 mm |
| SS600 | 600 mm | 730 mm | 390 mm | 705 mm | 430 mm | - | - |
| SS800 | 770 mm | 930 mm | 580 mm | 880 mm | 480 mm | - | - |
| Aluminium | Throat | Width | Height | Width | Height | Width | Height |
| AA500 | 500 mm | 640 mm | 320 mm | 610 mm | 415 mm | 750 mm | 190 mm |
| AA600 | 600 mm | 730 mm | 390mm | 705 mm | 430 mm | - | - |

Bases

Ampelair ventilators can be supplied complete with a base to suit any application, or heads and bases can be ordered separately. Roof pitch and roofing profile must be specified at time of ordering bases. Heavy duty bases are made from Zinalume®, and supplied in natural finish, but Colorbond® colours can be supplied if specified.

Square to Round – Zinalume®

Available for models: SS150, SS300, SS500, SS600, SS800.

Variable Pitch – Stainless Steel

Available for models: SS300, SS500.

Variable Pitch – Aluminium available for model: AA500.

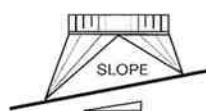

The most widely used base type. Roof pitch must be specified when ordering.

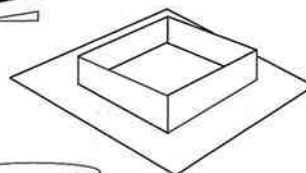

Square to round bases are supplied with roof tray which must be installed according to Ampelair fixing instructions overleaf.

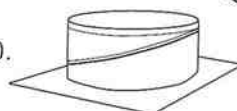

Variable pitch stainless steel or aluminium base and flashing.

Note:

Base flashings are powder coated to avoid dis-similar metal contact.

Dampers

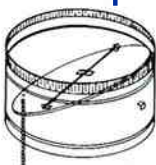

Available ex stock for 300 mm, 500 mm, and 600 mm throat diameter ventilators. Smaller sizes are not widely used but can be supplied against orders.

Manually operated. Zinalume® construction.

TEN YEAR WARRANTY

Details of the Ampelair warranty are available from Ampelite Australia Pty Ltd offices. Specific written project warranties will be provided upon verification of correct installation procedures.



Ampelair

Aluminium ventilators. For less intensive environments

- Featuring the same mechanical specifications as the Stainless Steel range.
- Models/Sizes: AA500 mm, AA600mm. See dimension table for base types available.



CAPACITY TABLE

Extraction volume expressed as cubic metres per second.

1 cubic metre = 1000 litres

| Stack Height Metres | Wind Speed Km/hr. | Temp Diff. °C | Model S5/AA | | | | | |
|------------------------|----------------------|------------------|-------------|-------|-------|-------|-------|-------|
| | | | 150 | 300 | 500 | 600 | 800 | |
| 3.0 | 6 | 6 | 0.038 | 0.152 | 0.350 | 0.609 | 0.952 | |
| | | 12 | 0.039 | 0.158 | 0.362 | 0.630 | 0.985 | |
| | | 18 | 0.042 | 0.166 | 0.382 | 0.664 | 1.038 | |
| | 8 | 6 | 0.045 | 0.182 | 0.419 | 0.727 | 1.137 | |
| | | 12 | 0.046 | 0.184 | 0.428 | 0.738 | 1.154 | |
| | | 18 | 0.049 | 0.193 | 0.452 | 0.785 | 1.228 | |
| | 6.0 | 6 | 6 | 0.068 | 0.272 | 0.625 | 1.088 | 1.700 |
| | | | 12 | 0.069 | 0.277 | 0.635 | 1.105 | 1.729 |
| | | | 18 | 0.070 | 0.279 | 0.641 | 1.116 | 1.736 |
| 8 | | 6 | 0.084 | 0.336 | 0.772 | 1.343 | 2.099 | |
| | | 12 | 0.086 | 0.344 | 0.791 | 1.377 | 2.153 | |
| | | 18 | 0.088 | 0.352 | 0.808 | 1.408 | 2.197 | |
| 9.0 | | 6 | 6 | 0.039 | 0.158 | 0.362 | 0.630 | 0.985 |
| | | | 12 | 0.046 | 0.183 | 0.420 | 0.732 | 1.145 |
| | | | 18 | 0.047 | 0.189 | 0.431 | 0.751 | 1.175 |
| | 8 | 6 | 0.046 | 0.184 | 0.424 | 0.738 | 1.154 | |
| | | 12 | 0.048 | 0.191 | 0.439 | 0.763 | 1.194 | |
| | | 18 | 0.050 | 0.199 | 0.458 | 0.797 | 1.246 | |
| | 12 | 6 | 0.069 | 0.277 | 0.635 | 1.105 | 1.729 | |
| | | 12 | 0.071 | 0.285 | 0.655 | 1.141 | 1.784 | |
| | | 18 | 0.072 | 0.310 | 0.713 | 1.239 | 1.937 | |
| 16 | 6 | 0.086 | 0.344 | 0.791 | 1.377 | 2.153 | | |
| | 12 | 0.089 | 0.354 | 0.813 | 1.414 | 2.211 | | |
| | 18 | 0.092 | 0.367 | 0.844 | 1.467 | 2.294 | | |
| 12 | 6 | 6 | 0.042 | 0.166 | 0.381 | 0.664 | 1.038 | |
| | | 12 | 0.047 | 0.180 | 0.431 | 0.751 | 1.175 | |
| | | 18 | 0.052 | 0.210 | 0.483 | 0.839 | 1.312 | |
| | 8 | 6 | 0.049 | 0.196 | 0.452 | 0.785 | 1.228 | |
| | | 12 | 0.050 | 0.209 | 0.458 | 0.797 | 1.246 | |
| | | 18 | 0.058 | 0.230 | 0.530 | 0.922 | 1.441 | |
| | 12 | 6 | 0.070 | 0.279 | 0.642 | 1.116 | 1.745 | |
| | | 12 | 0.077 | 0.300 | 0.712 | 1.239 | 1.937 | |
| | | 18 | 0.080 | 0.321 | 0.737 | 1.283 | 2.007 | |
| 16 | 6 | 0.088 | 0.352 | 0.808 | 1.408 | 2.197 | | |
| | 12 | 0.092 | 0.367 | 0.843 | 1.467 | 2.294 | | |
| | 18 | 0.093 | 0.371 | 0.855 | 1.486 | 2.324 | | |

The formulas on page two and the above capacity table are useful guides to determining the model size and number of ventilators required.

Building usage, and other factors, finally determine the exact requirements for maximum efficiency and the comfort levels required. Ampelite can assist at design or specification stages in this regard.

Ampelair

Turbo Ventilators are a quality product from

AMPELITE
Makes light work!

Ampelite Australia Pty Ltd ABN 91 487 122 629

Vic & Tas: Tel 03 9794 0977. Fax 03 9794 0710. NSW: & ACT Tel 02 9625 7200. Fax 02 9625 7211.

Qld: Tel 07 3808 6211. Fax 07 3808 4799. SA & NT: Tel 08 8260 7391. Fax 08 8260 7397.

WA: Tel 08 9302 6833. Fax 08 9302 6855 NZ: Tel 09 634 5366. Fax 09 622 2060.

www.ampelite.com.au

Definitions

Stack Height

This is a measurement taken from the middle of the intake area to the base of the ventilator.

Wind Speed

Average or usual wind speed (Km/hr) at the location.

Temperature Differential

The average difference between internal and external temperatures.

INSTALLATION

1. It is recommended for rotary sizes 500 and up, solid support between purlins is installed. Failure to do so can result in needless movement of the vent in high winds. Failure to provide correct support may result in loss of warranty.
2. It is recommended back trays to ridge capping or roof expansion joints are used to provide guaranteed leak proof installation. Photo below shows back tray extending beneath roof expansion joint.



3. Drawing shows soaker installation without a back tray.

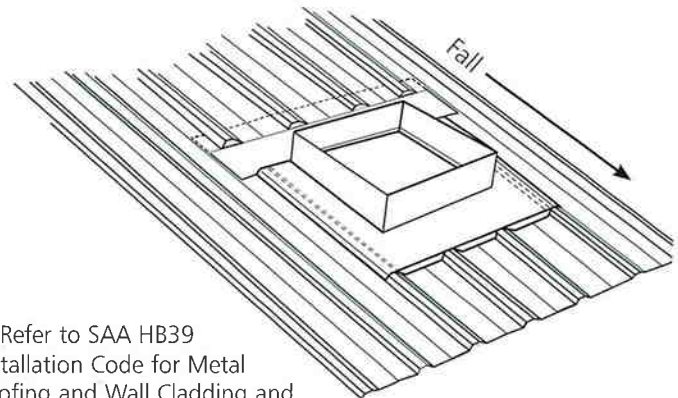

4. Refer to SAA HB39 Installation Code for Metal Roofing and Wall Cladding and install accordingly.

SPECIFICATION

The Wind Driven Ventilators shall be "Ampelair" Model (insert) made from *Stainless Steel / Aluminium
**in natural finish/coloured to match
Colorbond®.....
Installation shall be in accordance with Ampelair fixing instructions and closely follow SAA HB39 installation procedures. All work shall be done in workmanlike manner.
*Insert/select whichever required. **Select/insert finish required.

Ampelite is wholly Australian owned. Profits remain in Australia and taxes paid benefit our community.



Quality System
Quality Endorsed Company
AS/NZS ISO 9001
QEC 4787
Standards Australia